



Matthias Bräuer

**Design and Prototypical Implementation of a Pivot
Model as Exchange Format for Models and
Metamodels in a QVT/OCL Development Environment**

Großer Beleg – Progress Report

Contents

- Introduction
- Theoretical Foundations
- Tools and Technology
- Problem Analysis
- Related Work
- Results
- Discussion

Contents

- Introduction
- Theoretical Foundations
- Tools and Technology
- Problem Analysis
- Related Work
- Results
- Discussion

What does “Pivot Model” mean?

- Pivot ...

an **interpreter** that acts as a link between interpreters of alien languages

- Pivotal model ...

a (meta-) model that is the **bridge** between conceptually related (meta-) models

Problem and Motivation

- growing importance of domain-specific languages



Aim and Scope

- Design of a metamodel that can fulfill the role of a **Pivot Model** for OCL and arbitrary DSLs
- Prototypical implementation of **adaptation mechanism** considering requirements for model transformation
- Expressiveness limited to capabilities of **EssentialOCL** (OCL for EMOF)

Contents

- Introduction
- **Theoretical Foundations**
- Tools and Technology
- Problem Analysis
- Related Work
- Results
- Discussion

Ontological Classification Problem

- two dimensions of metamodeling

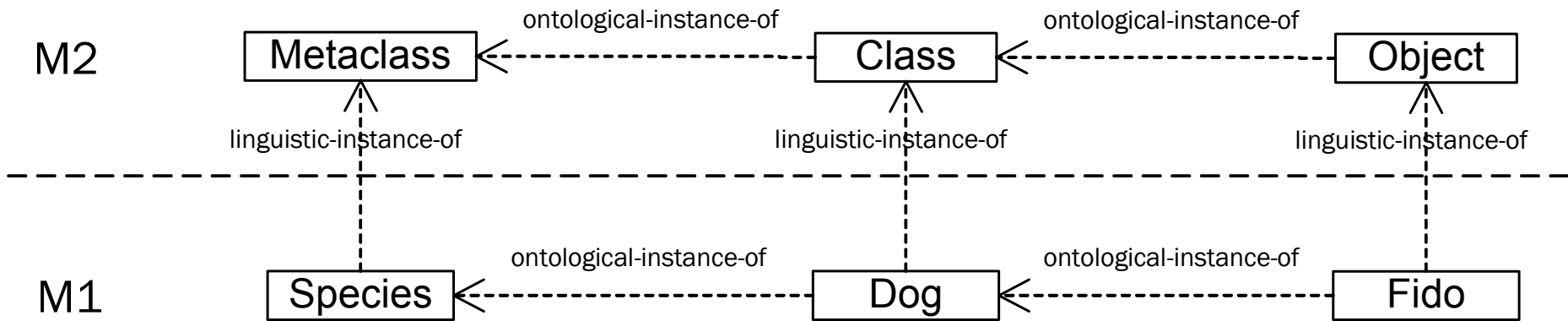

Ontological Classification Problem

- In UML: Stereotypes and Profiles **extend** M2 concepts
- DSLs define entirely **new** ontology concepts on M2

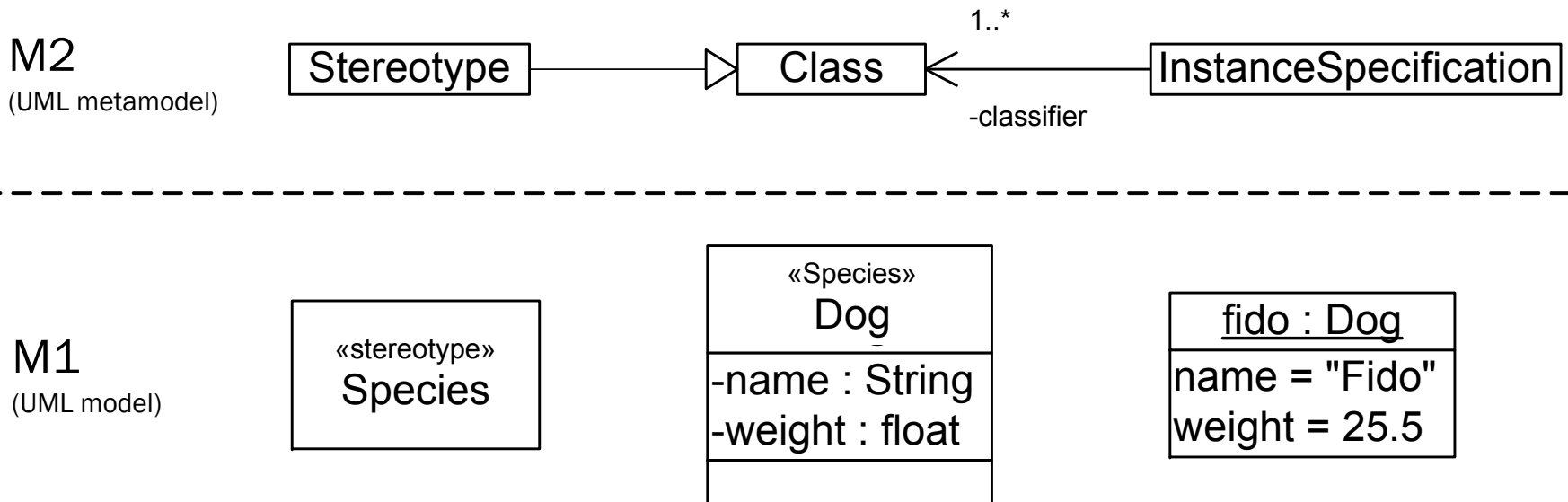

System Instantiation

Problem

- Transformation on the System layer requires instantiation of new System elements
- Instantiation semantics?

Model Space

System Space

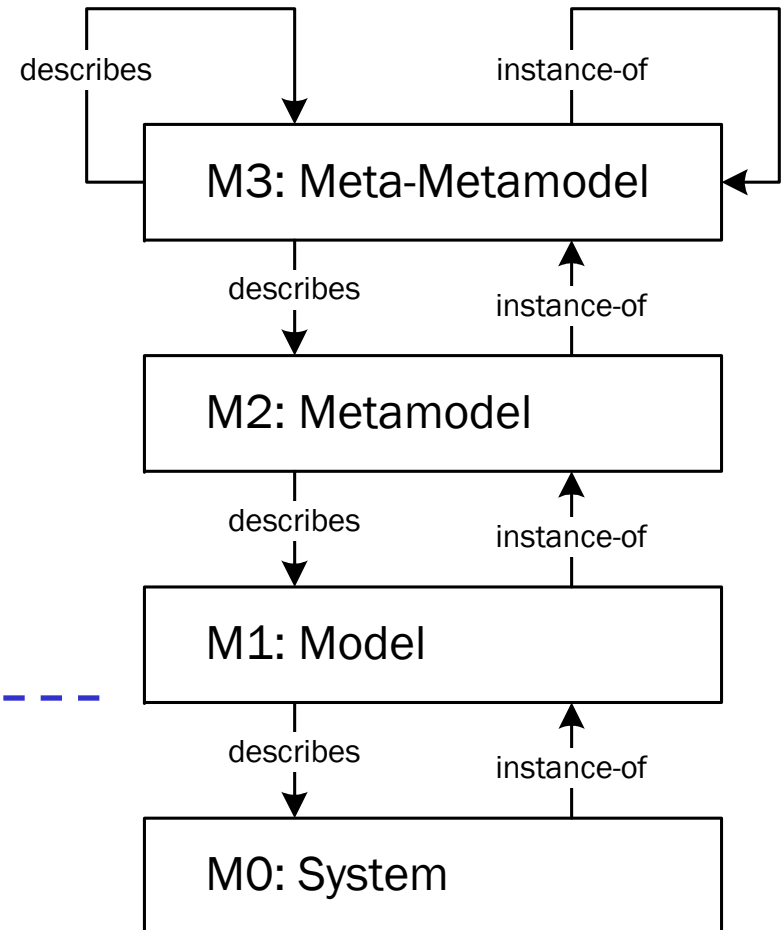

Contents

- Introduction
- Theoretical Foundations
- **Tools and Technology**
- Problem Analysis
- Related Work
- Results
- Discussion

Tools and Technology

- Eclipse as integration platform
- Rational Rose / EMF for modeling and code generation

Contents

- Introduction
- Theoretical Foundations
- Tools and Technology
- **Problem Analysis**
- Related Work
- Results
- Discussion

Usage Scenarios

- Constraint evaluation on M1 and M0
- Transformation on M1 and M0

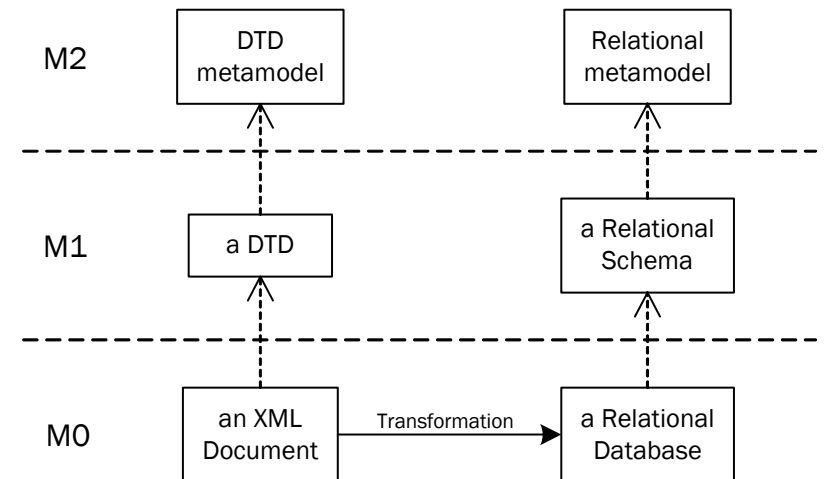
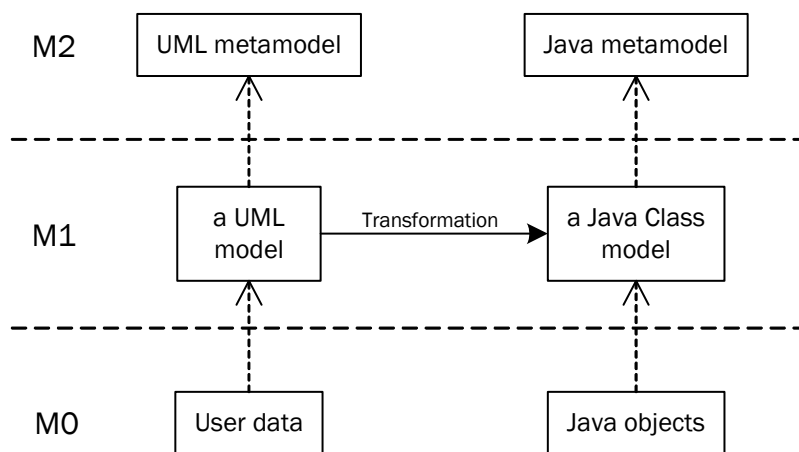

A Research Framework

- Three Layers of OCL integration

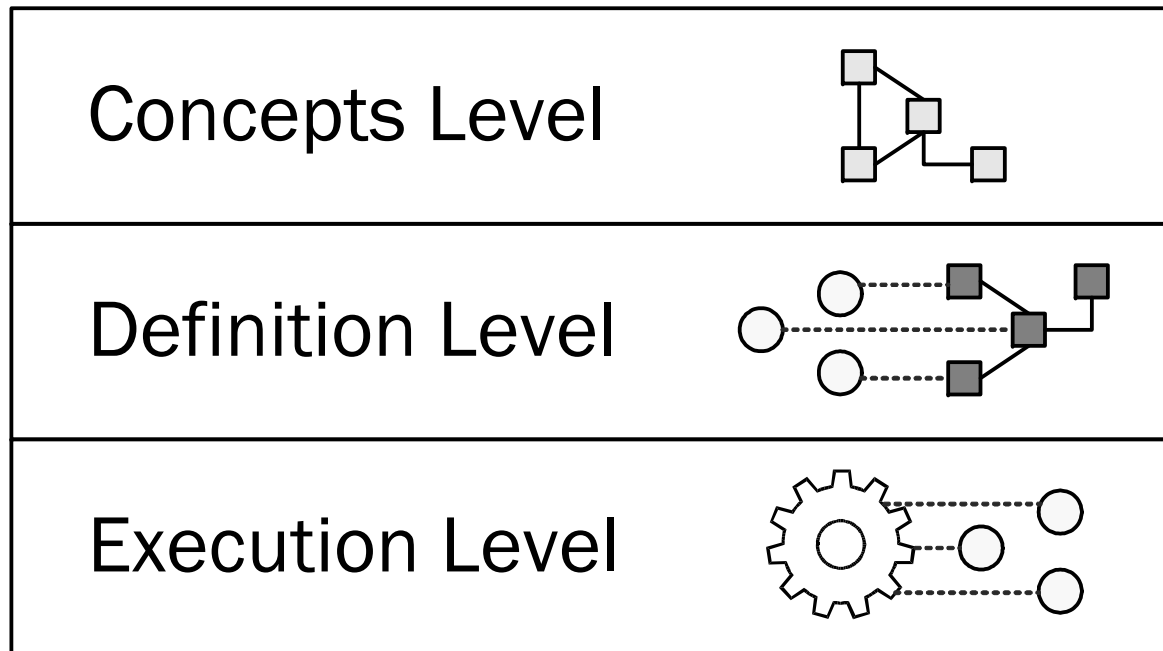

A Motivational Example

- PML ... Plugin Modeling Language

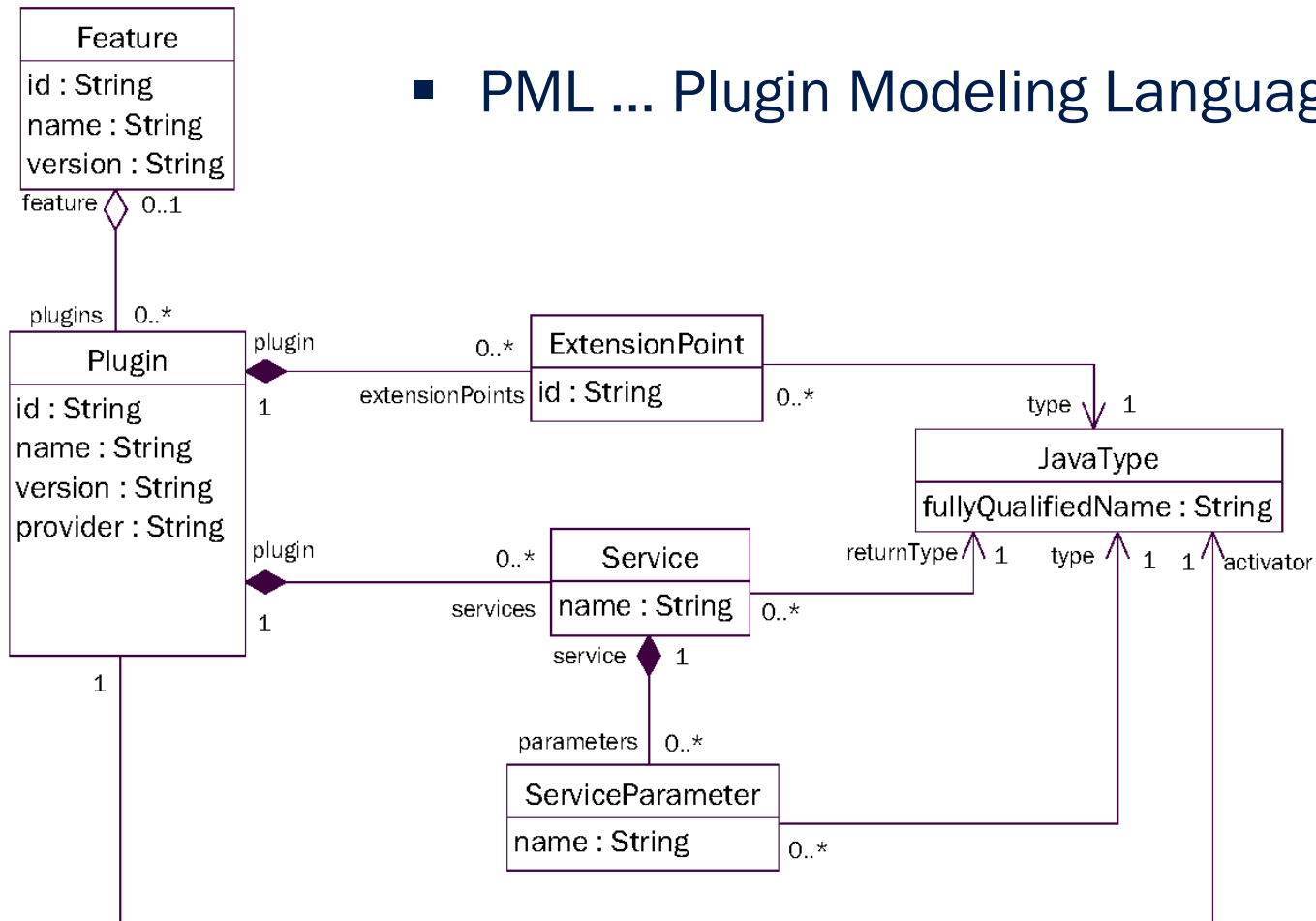

A PML model

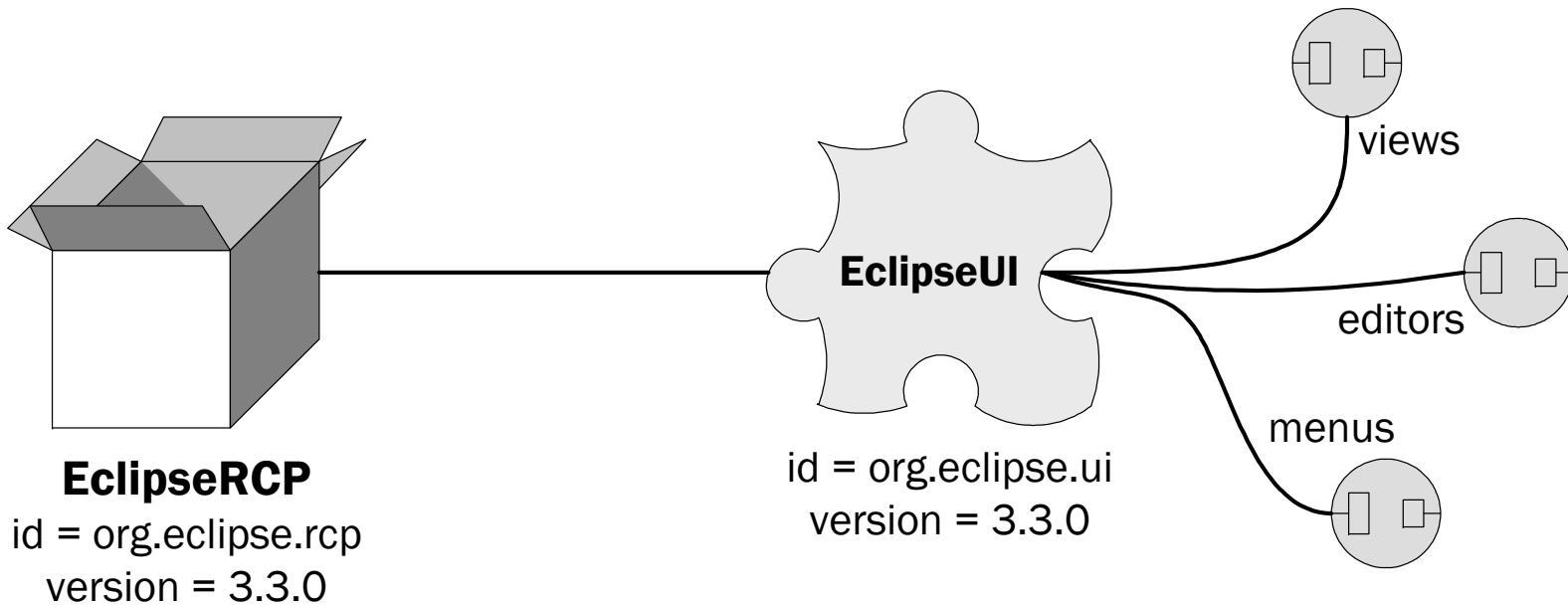

Relation to the Meta Hierarchy

-- a Plugin must have an ID
context Plugin
inv: self.id.notEmpty()

-- all Plugins in a Feature
 -- must be distinct
context Feature
inv: self.plugins->isUnique
 (plugin | plugin.id)

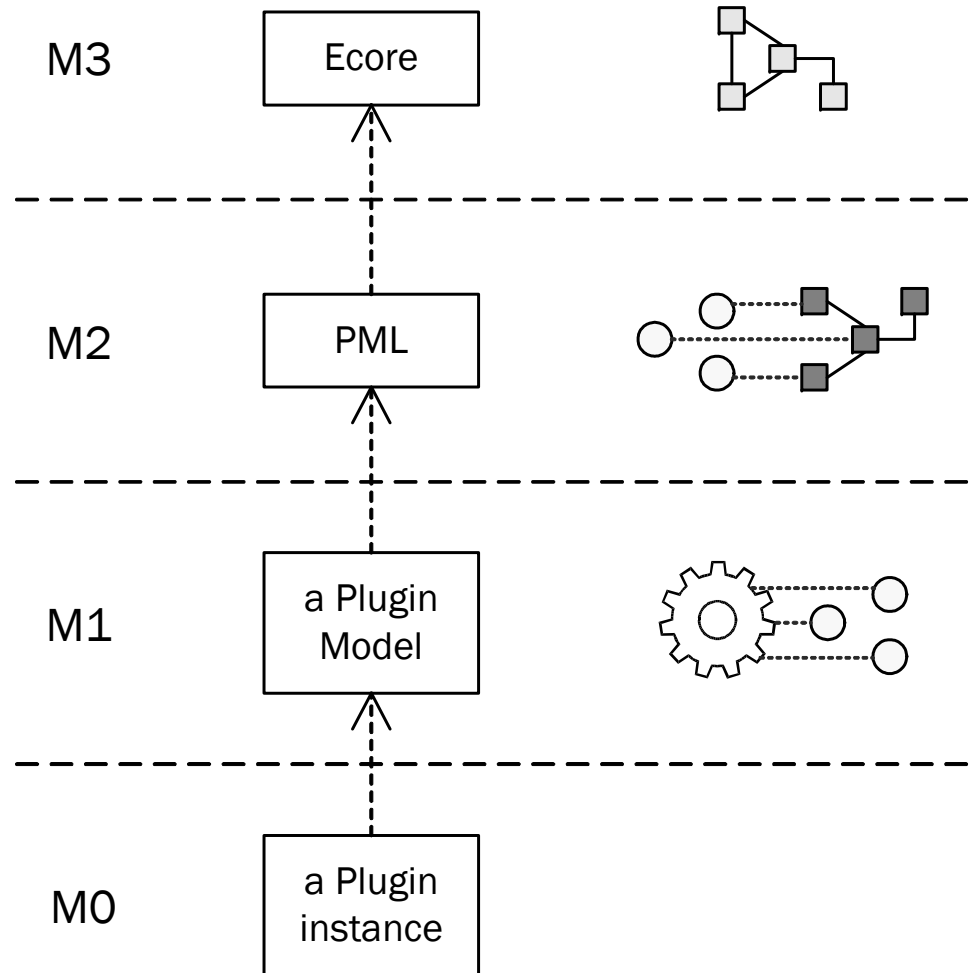

Relation to the Meta Hierarchy

context EclipseUI

-- there must be at least
-- one view extension

inv: views.notEmpty()

-- extension must implement
-- IViewPart

inv: views.isKindOf(org.
eclipse.ui.IViewPart)

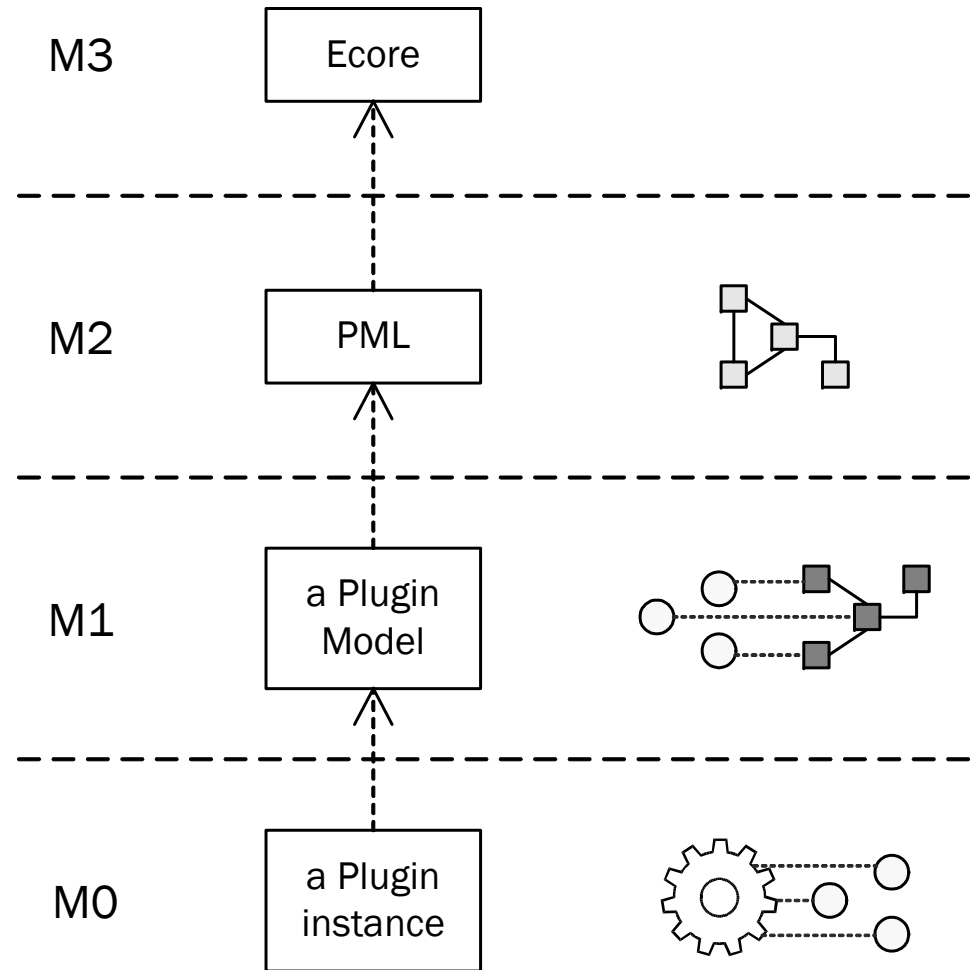

Concrete Requirements

1. Pivot Metamodel
2. Easy and flexible adaptation of arbitrary metamodels
3. Adaptation to different model repositories
4. Easy and flexible adaptation of runtime objects to OCL Standard Library

Contents

- Introduction
- Theoretical Foundations
- Tools and Technology
- Problem Analysis
- **Related Work**
- Results
- Discussion

Related Work

- Dresden OCL Toolkit
- MODELWARE / GMT Epsilon
- Kent OCL

Contents

- Introduction
- Theoretical Foundations
- Tools and Technology
- Problem Analysis
- Related Work
- **Results**
- Discussion

Results

- Realizing the Pivot Concept
- Prototypical Implementation

Realizing the Pivot Concept

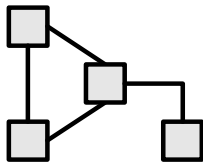

- Concepts Level
 - Analysis of research into **simplified** metamodels
 - Decision: no “Micro”-Pivotmodel

Concept Level of Dresden OCL Toolkit

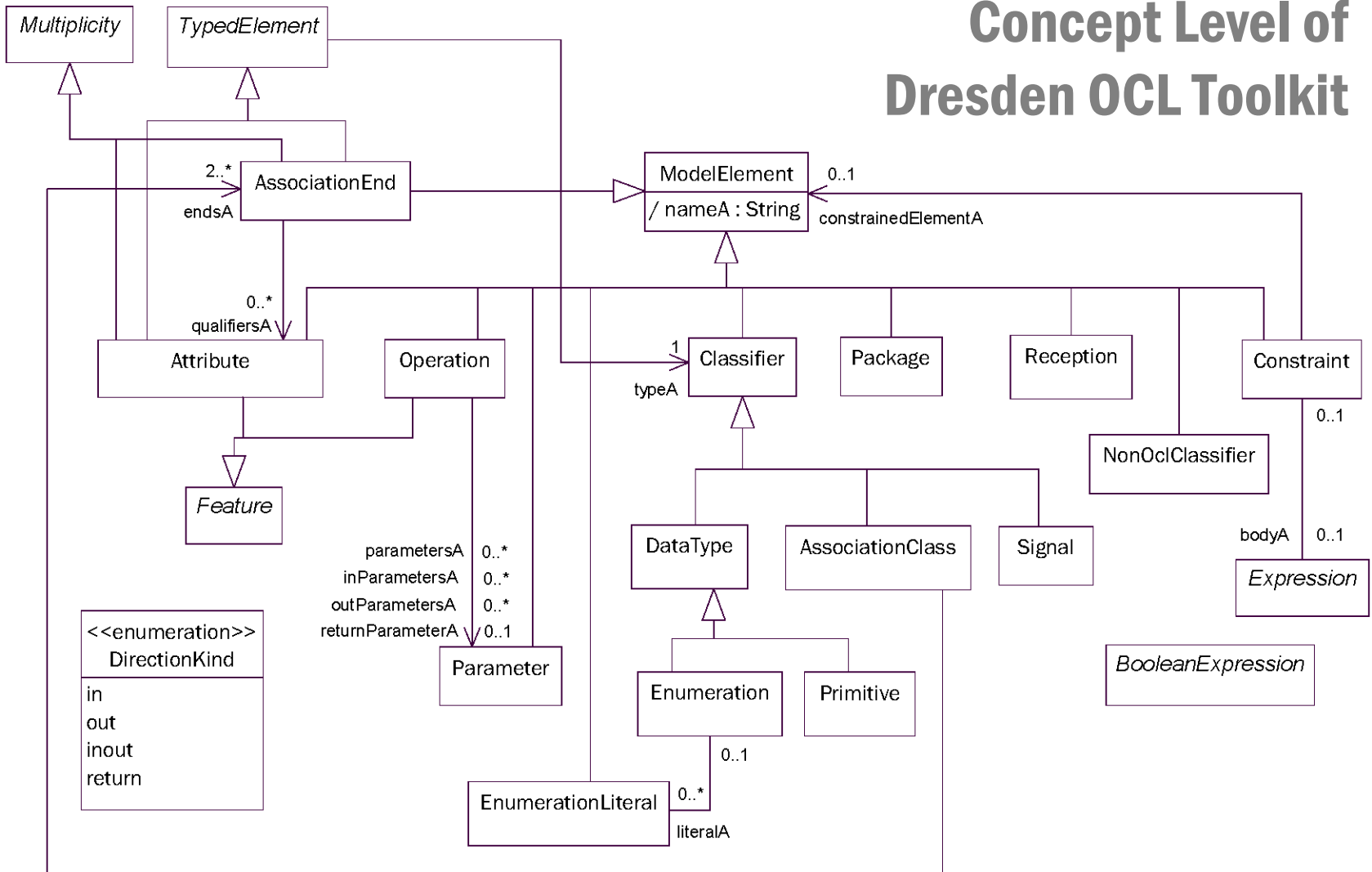

Concept Level of Dresden OCL Toolkit

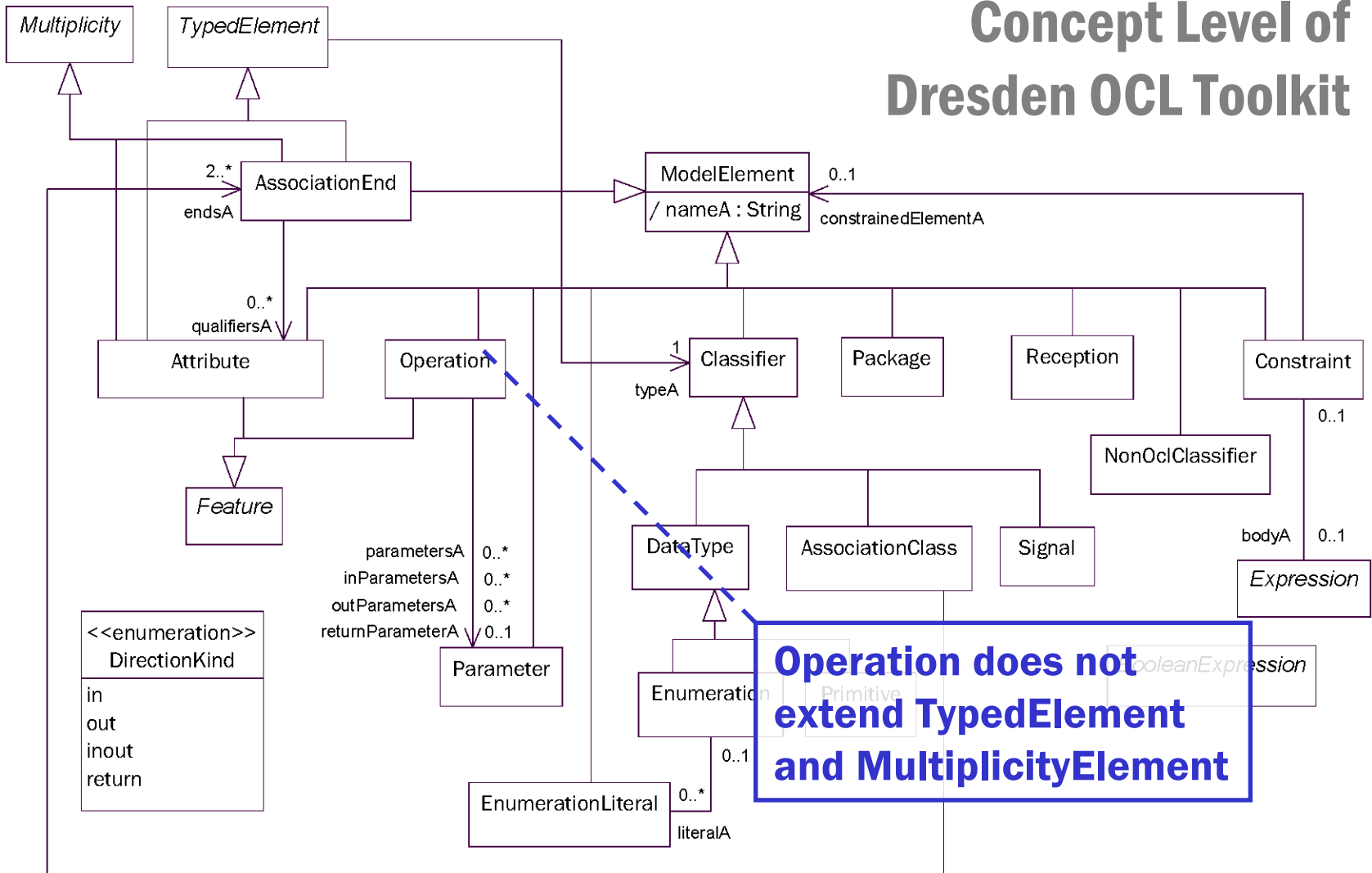

Concept Level of Kent OCL

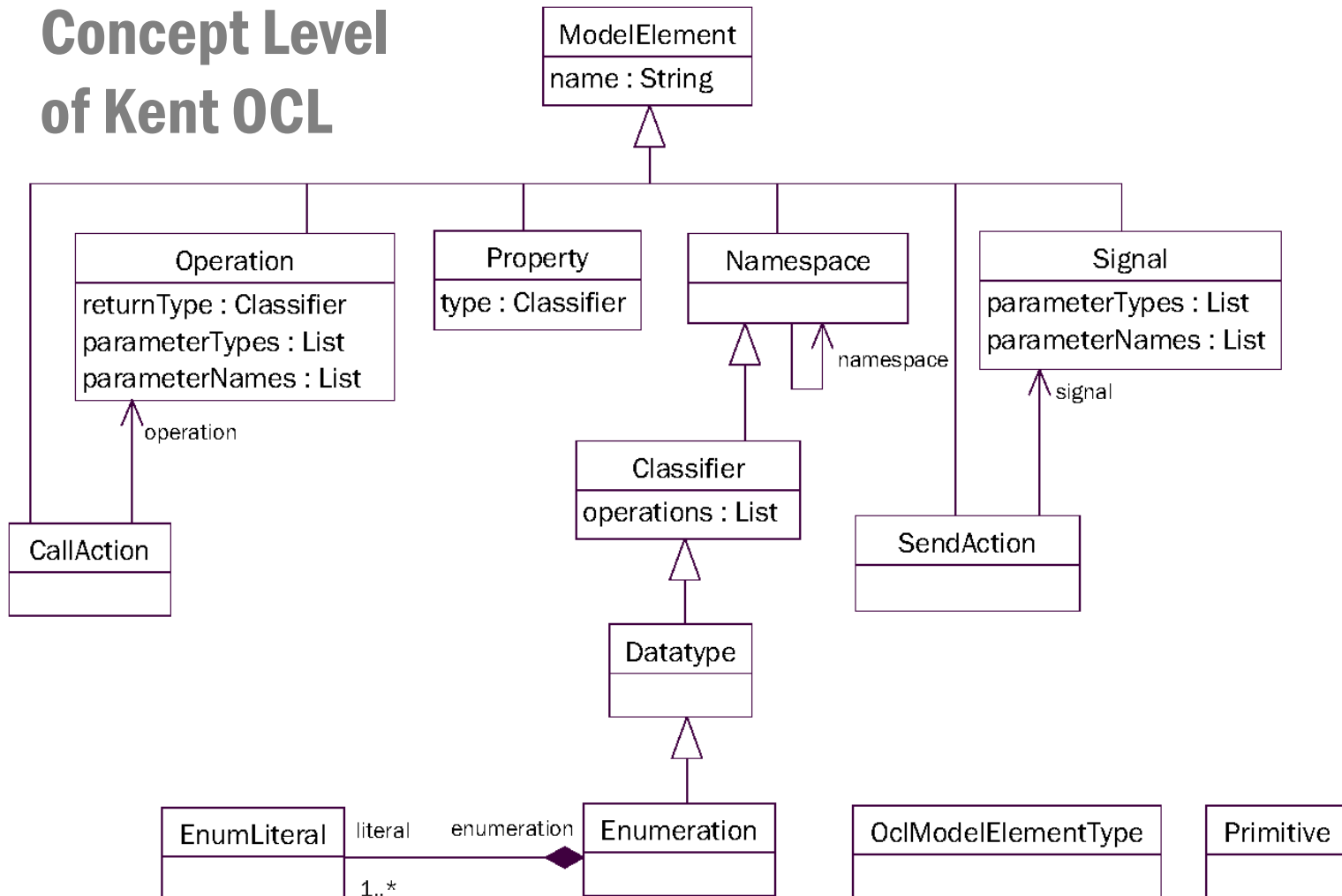

Concept Level of Kent OCL

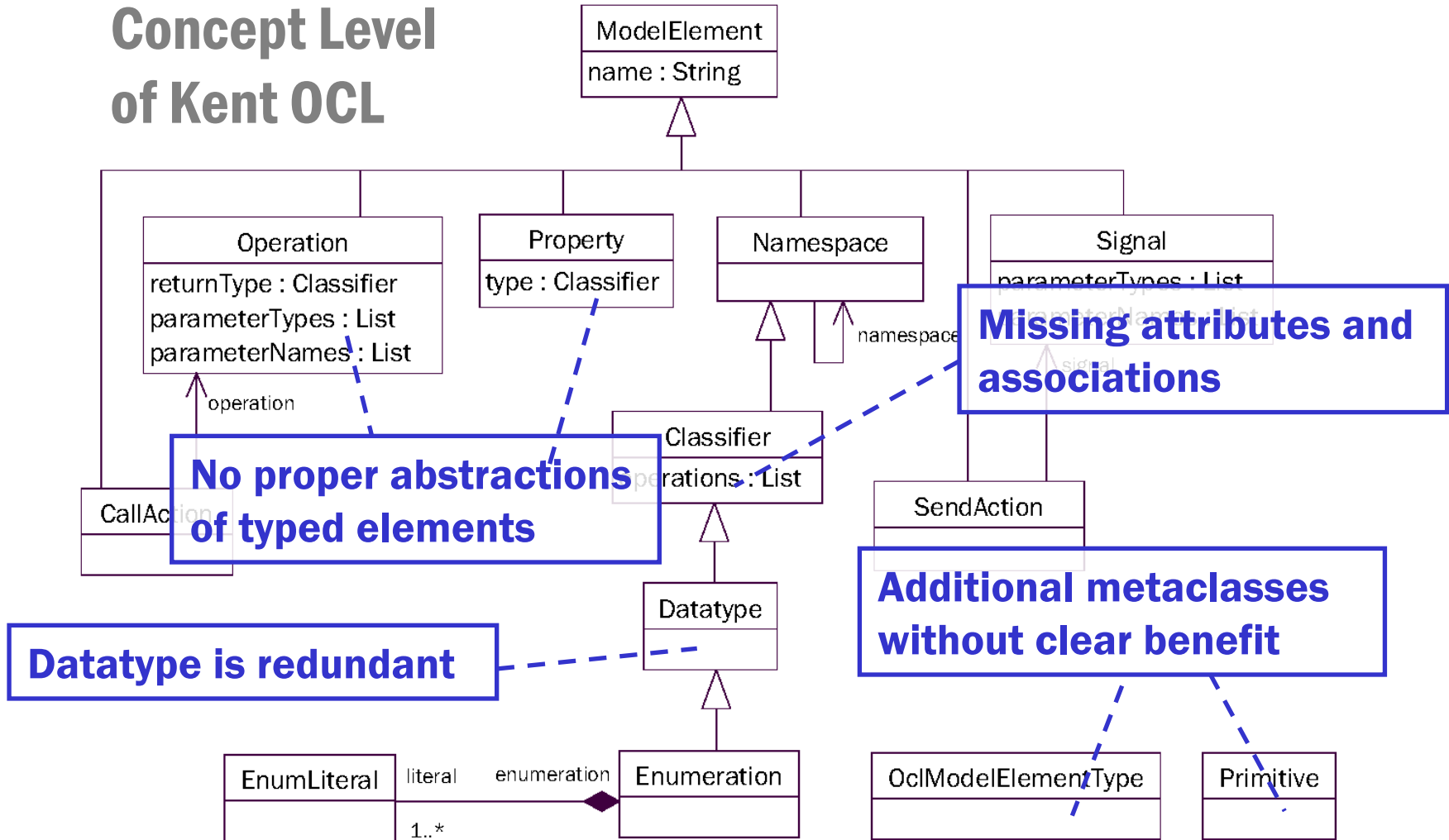

Concept Level of Kent OCL

- very complex
OCL type
hierarchy

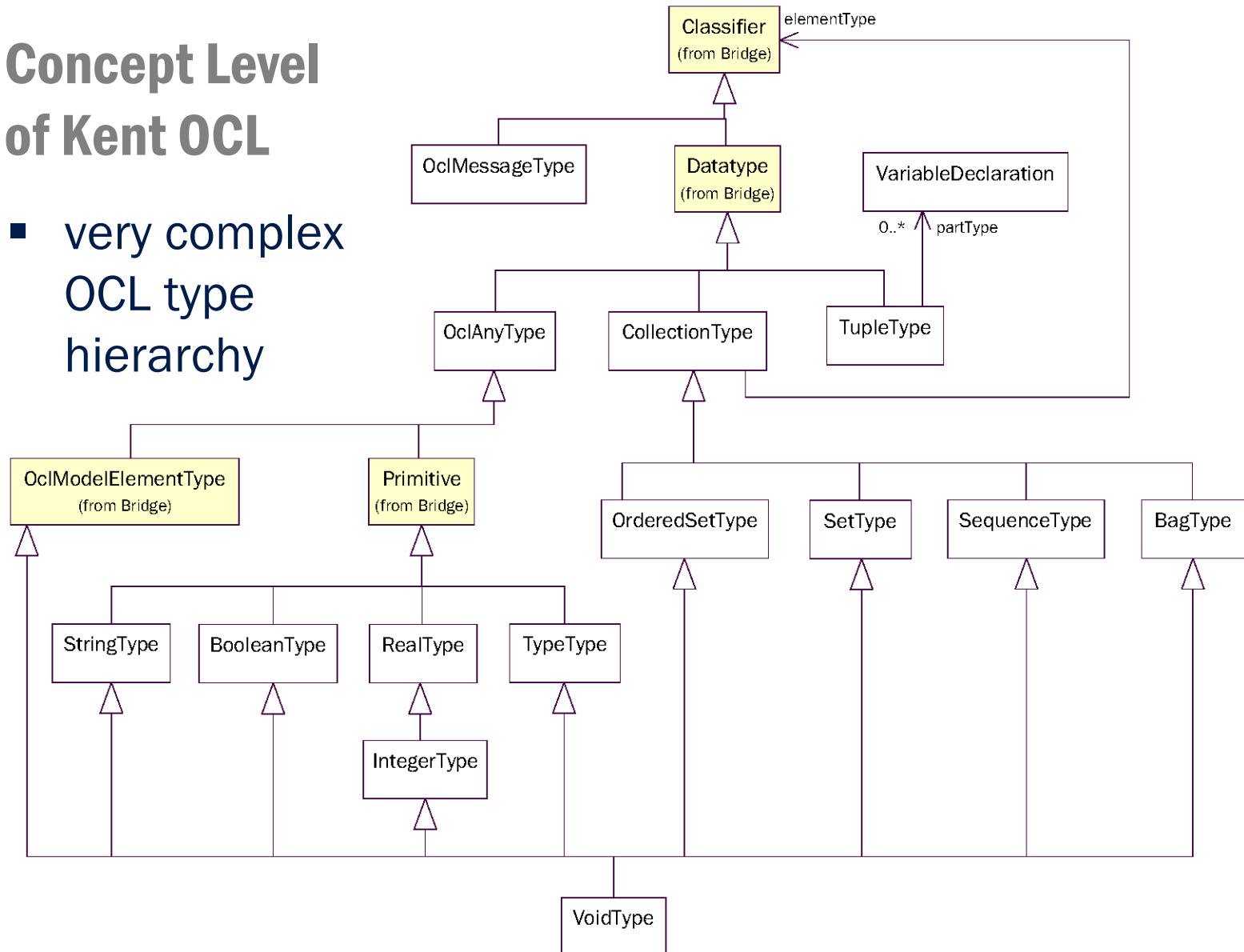

My approach

- Basis:
 - `Core::Basic` from UML Infrastructure Library
 - Definition of `EssentialOCL` in the OCL 2.0 Spec

- Guidelines:
 - a set of explicit `design principles`

Result

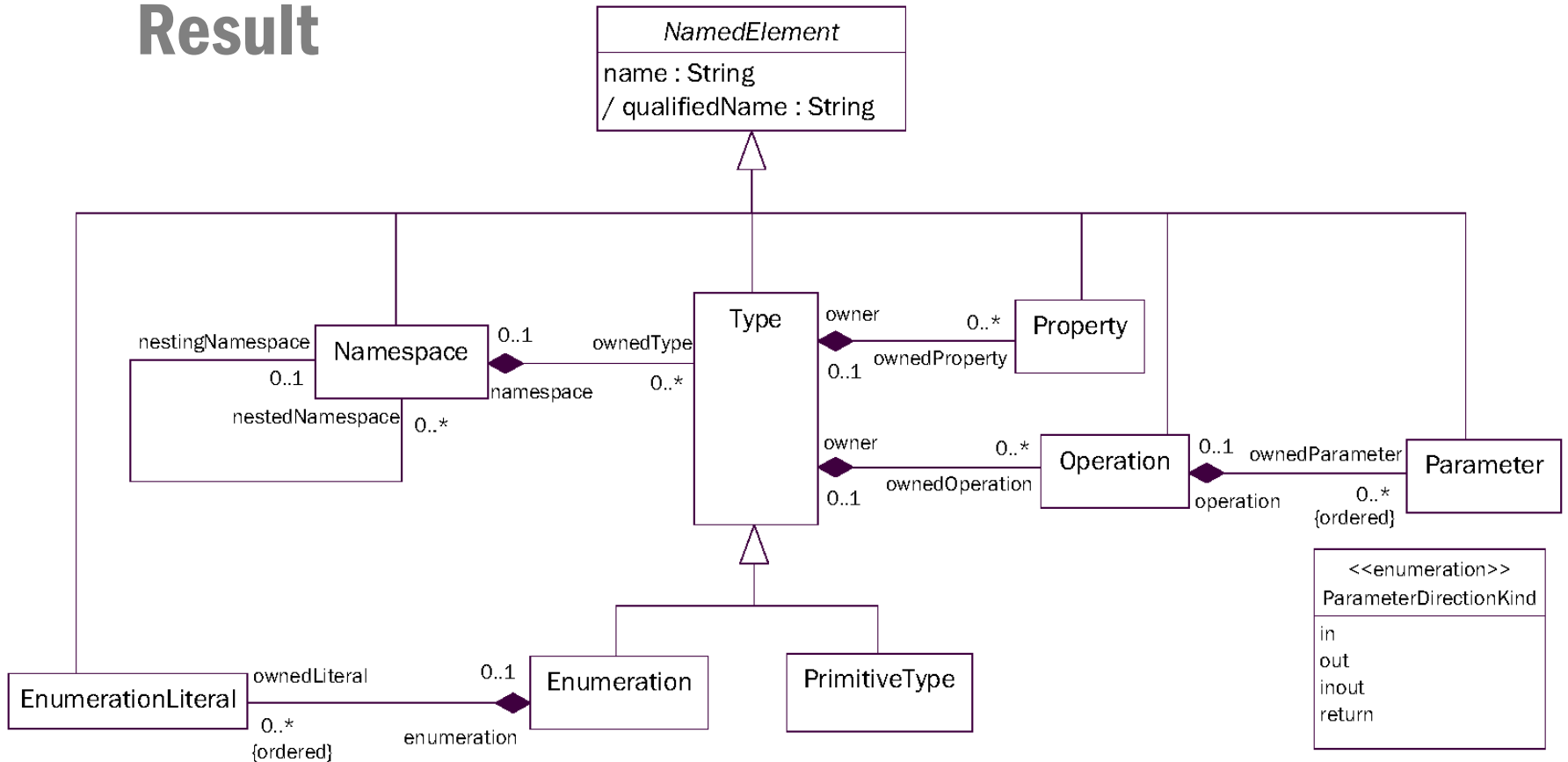

Adjusted OCL Type Hierarchy

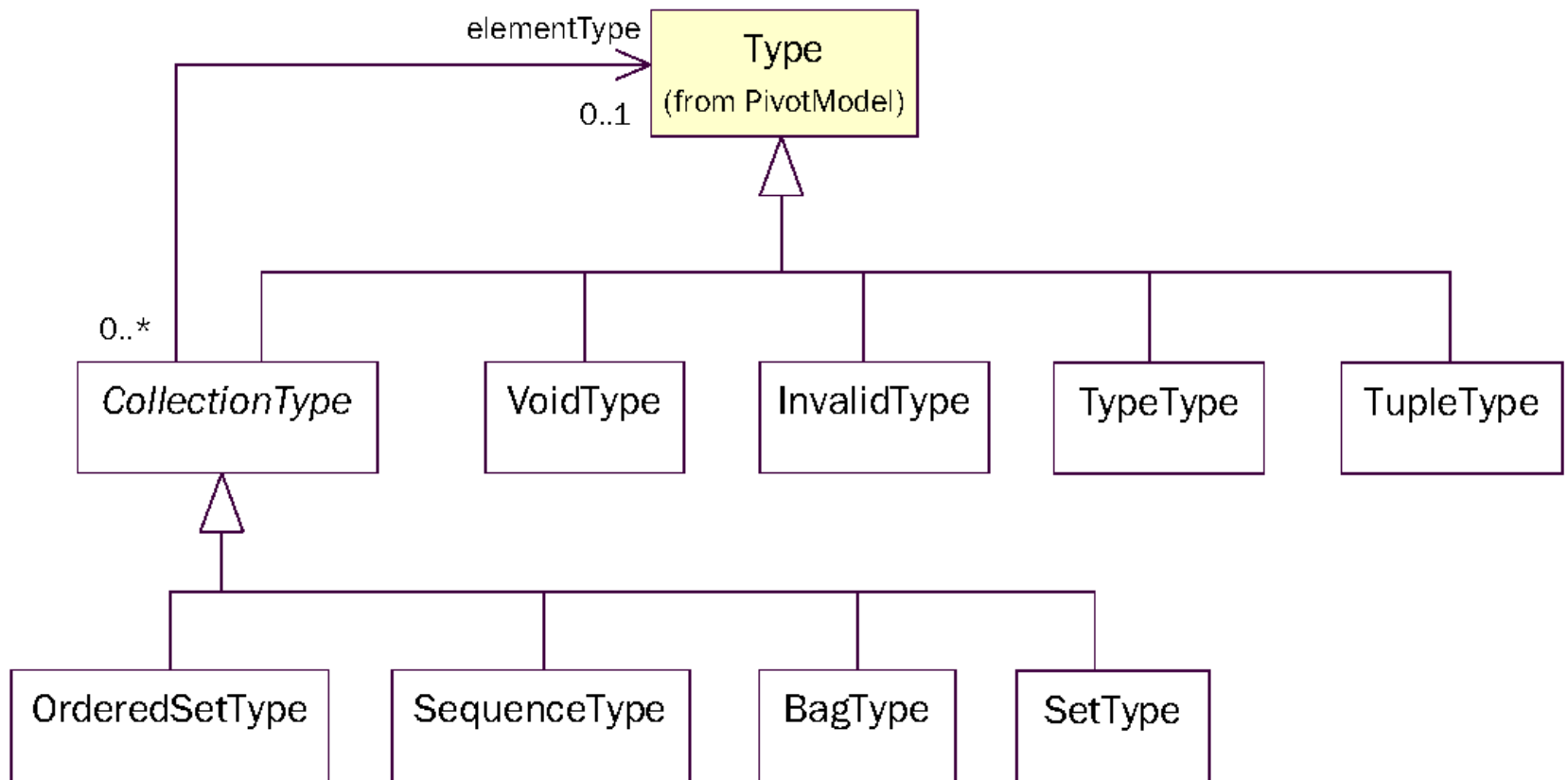

Realizing the Pivot Concept

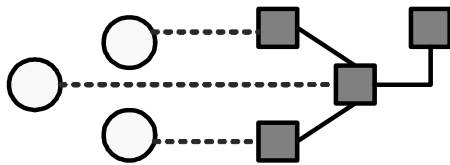

■ Definition Level

- Analysis of research into (meta-)model composition
- Metamodel **Merge** and Metamodel **Adaptation**
- Analysis of meta **repository** adaptation techniques

My approach

- Adaptation

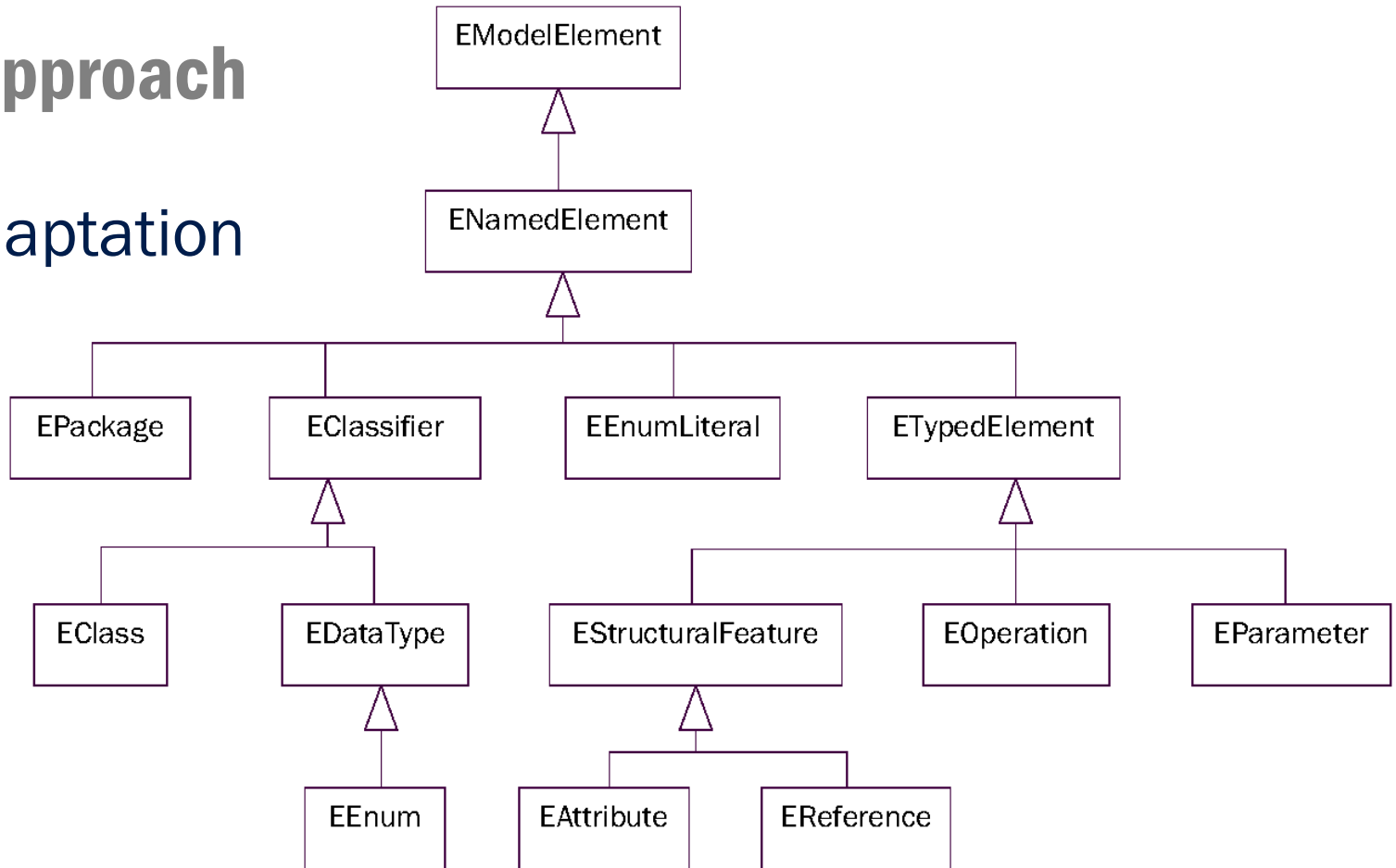

My approach

- Adaptation

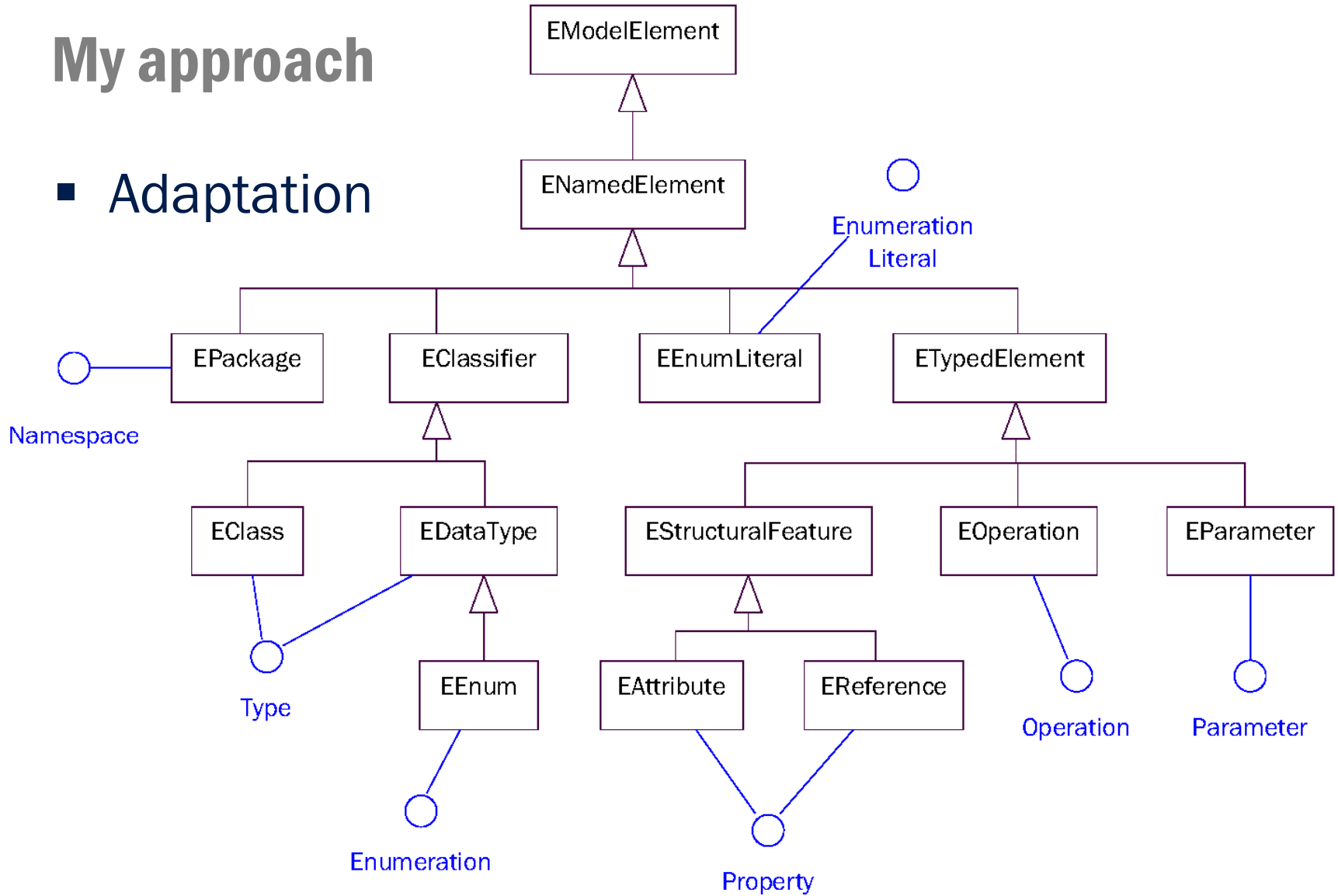

Adaptation by Delegation

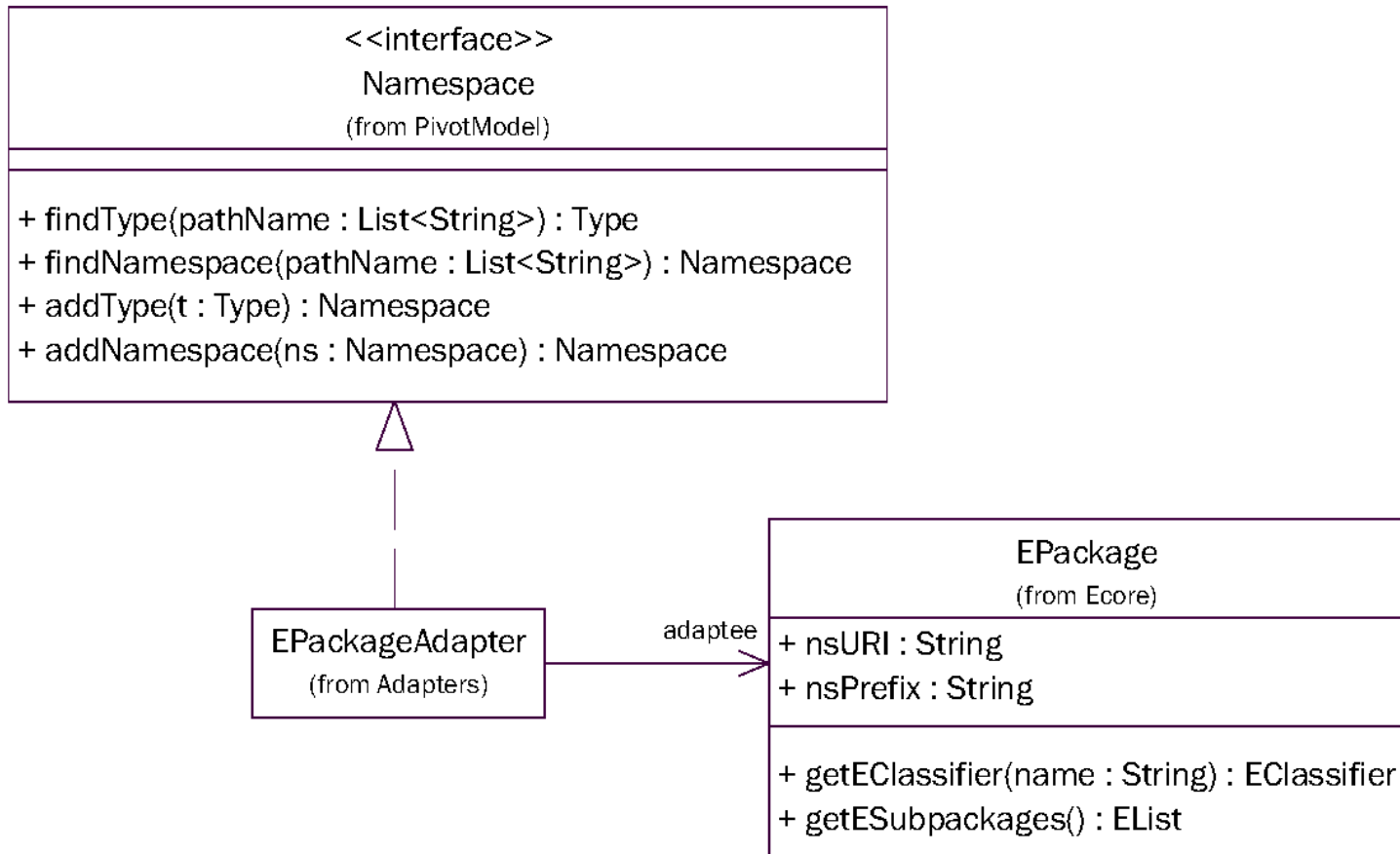

Adaptation for DSLs defined on M2

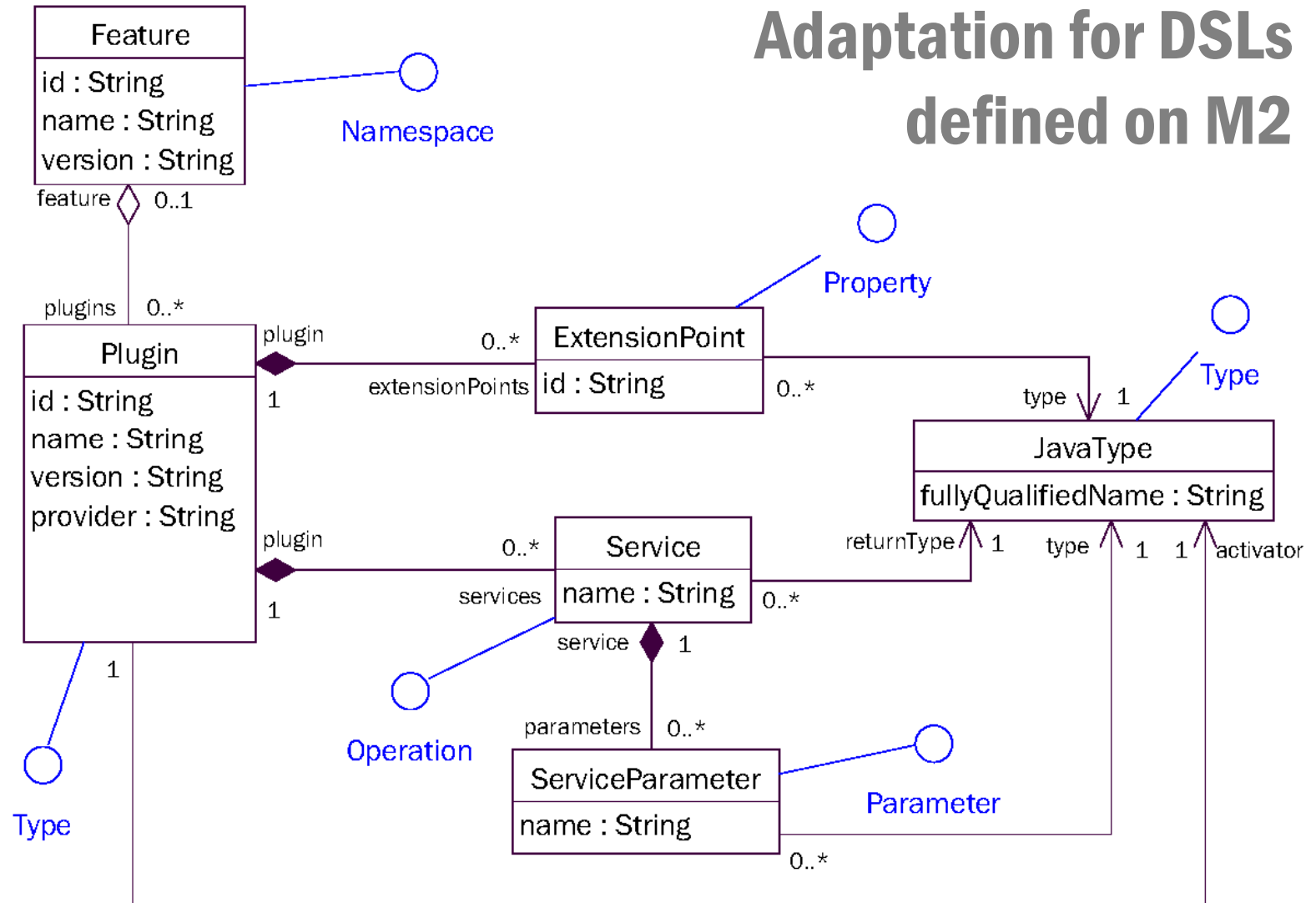

Repository Adaptation in Dresden OCL Toolkit

- UML-specific
- monolithic
(33 methods)

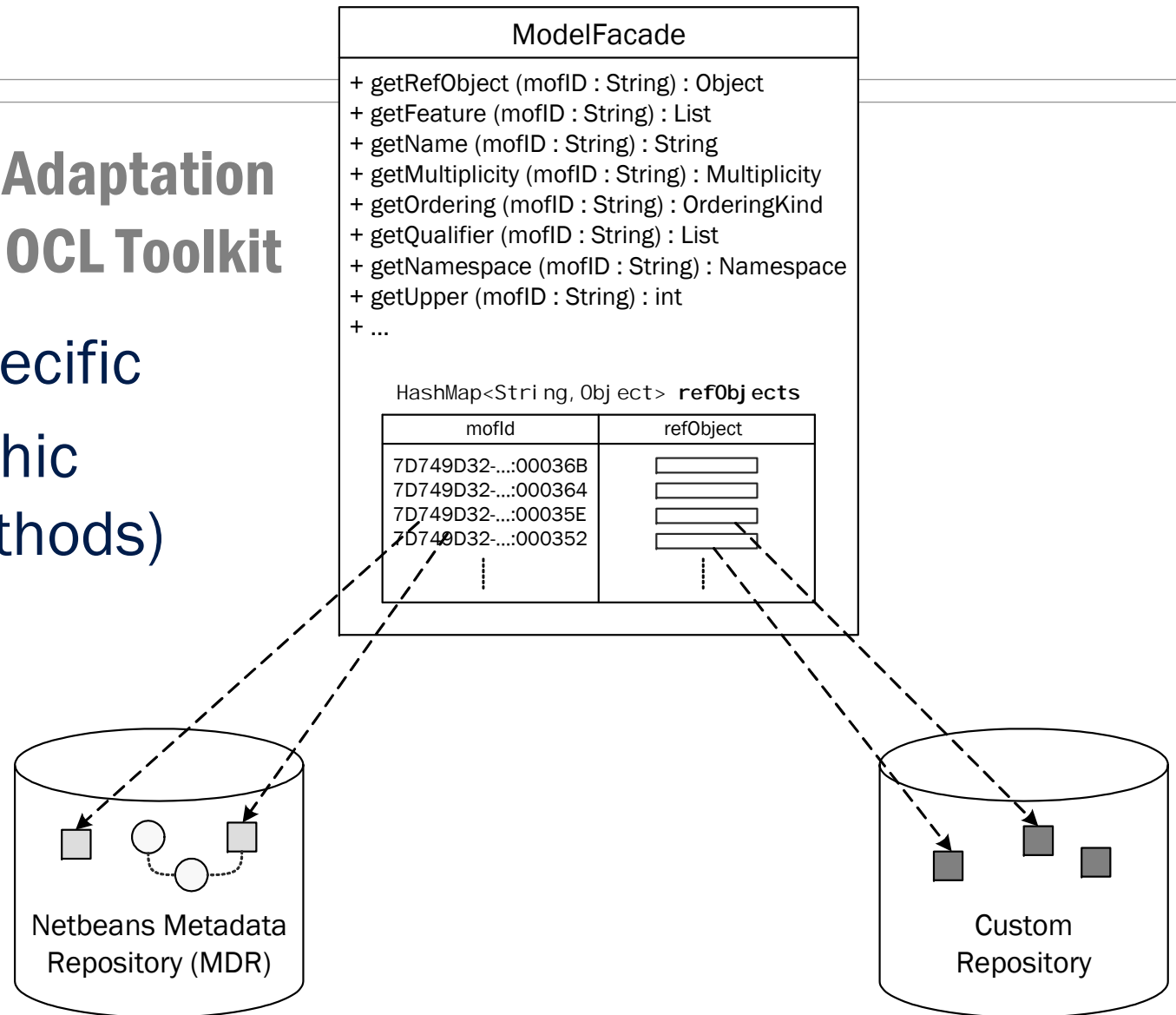

My approach

- reusing the DSL adapters

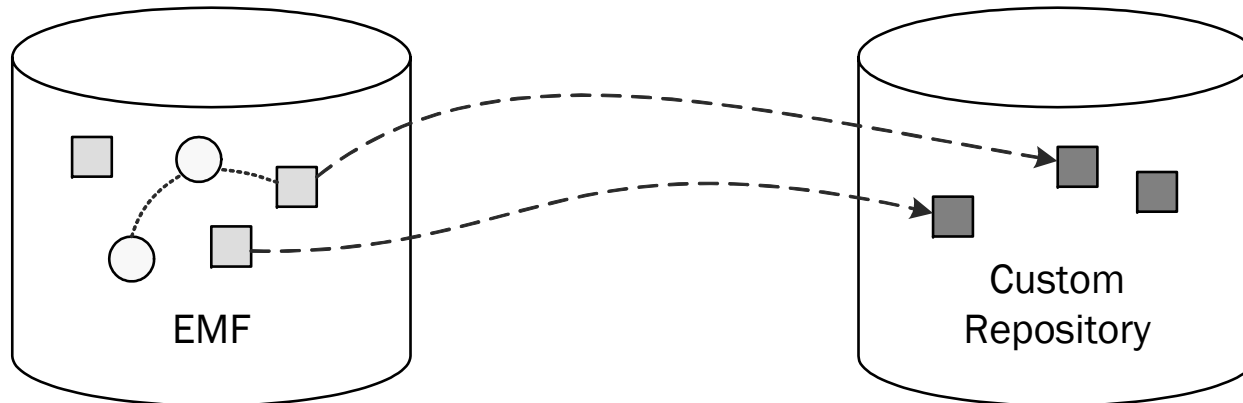

- DSL definition and instantiation not in the same repository \Rightarrow **Adapter Chaining**

Further issues

- Definition Level representation of the **Standard Library** (OclAny, OclInteger, ...)
 - some DSLs might not support inheritance
- “Adding“ properties and methods to the model via OCL **def**
- Solution: adapters provide “virtual view” on the real model

Realizing the Pivot Concept

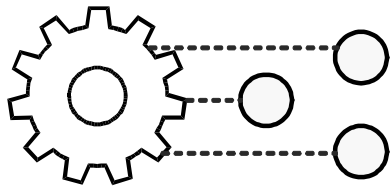

■ Execution Level

- Analysis of existing OCL implementations
- Analysis of required interface for OCL execution engine

Execution Level in Kent OCL

- Code Generation with fixed semantics

- Operations:

```
"oclBoolean " + result + " = " + temp1 + "." +  
operName + "("+temp2+");
```

- Properties:

```
source + "." +  
this.processor.getModelImplAdapter().  
getterName(propertyName) + "()";
```

Execution Level in Dresden OCL Toolkit

- Translation between OCL space and Model space
- **reflective** methods for getting properties and invoking operations

Mapping

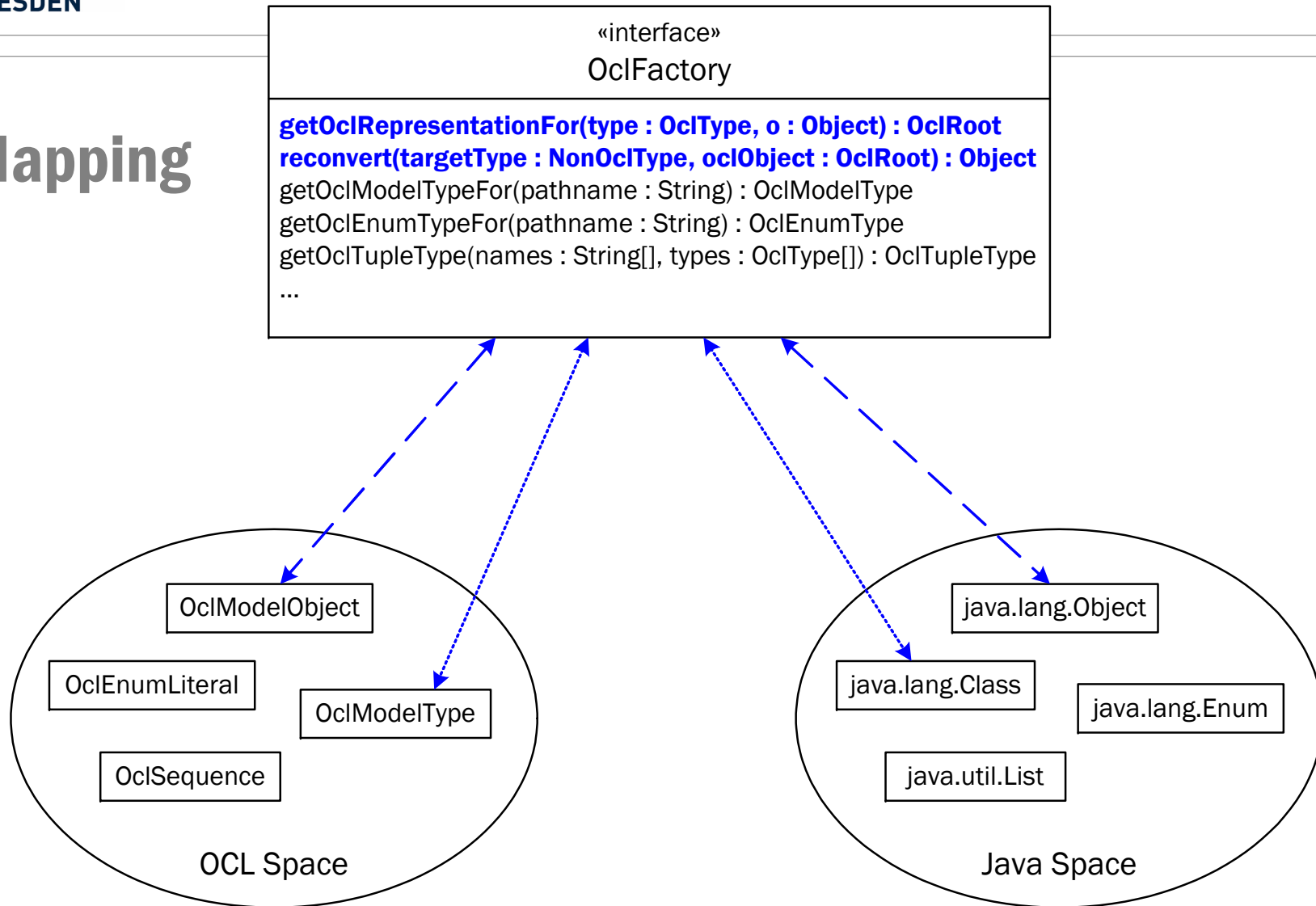

My approach

- Adaptation through delegation

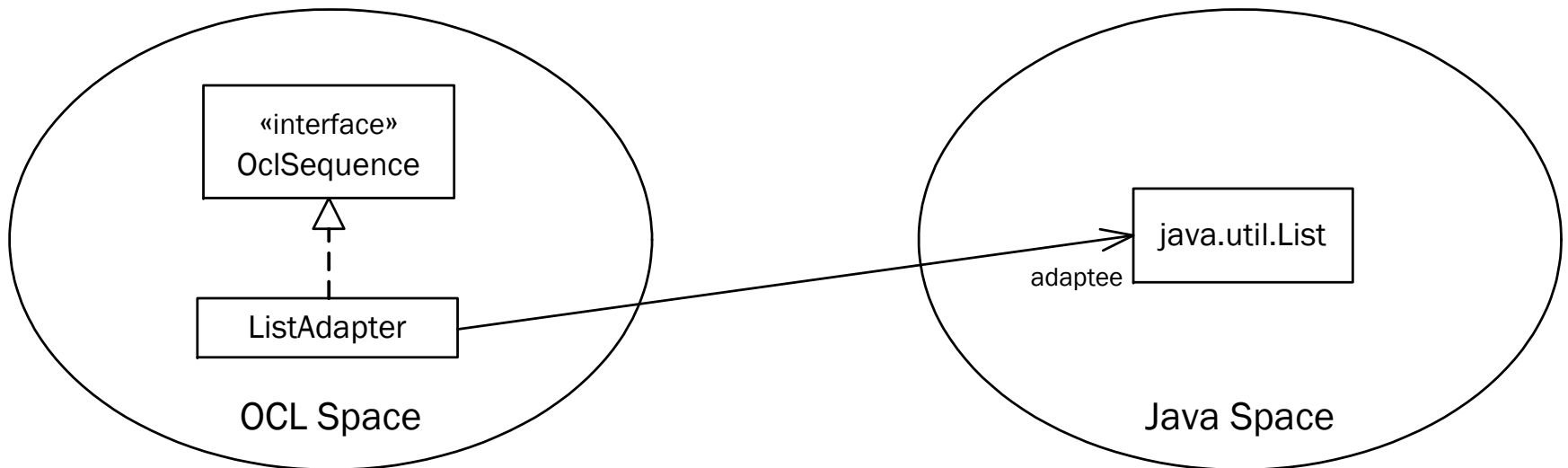

A new Base Library Hierarchy

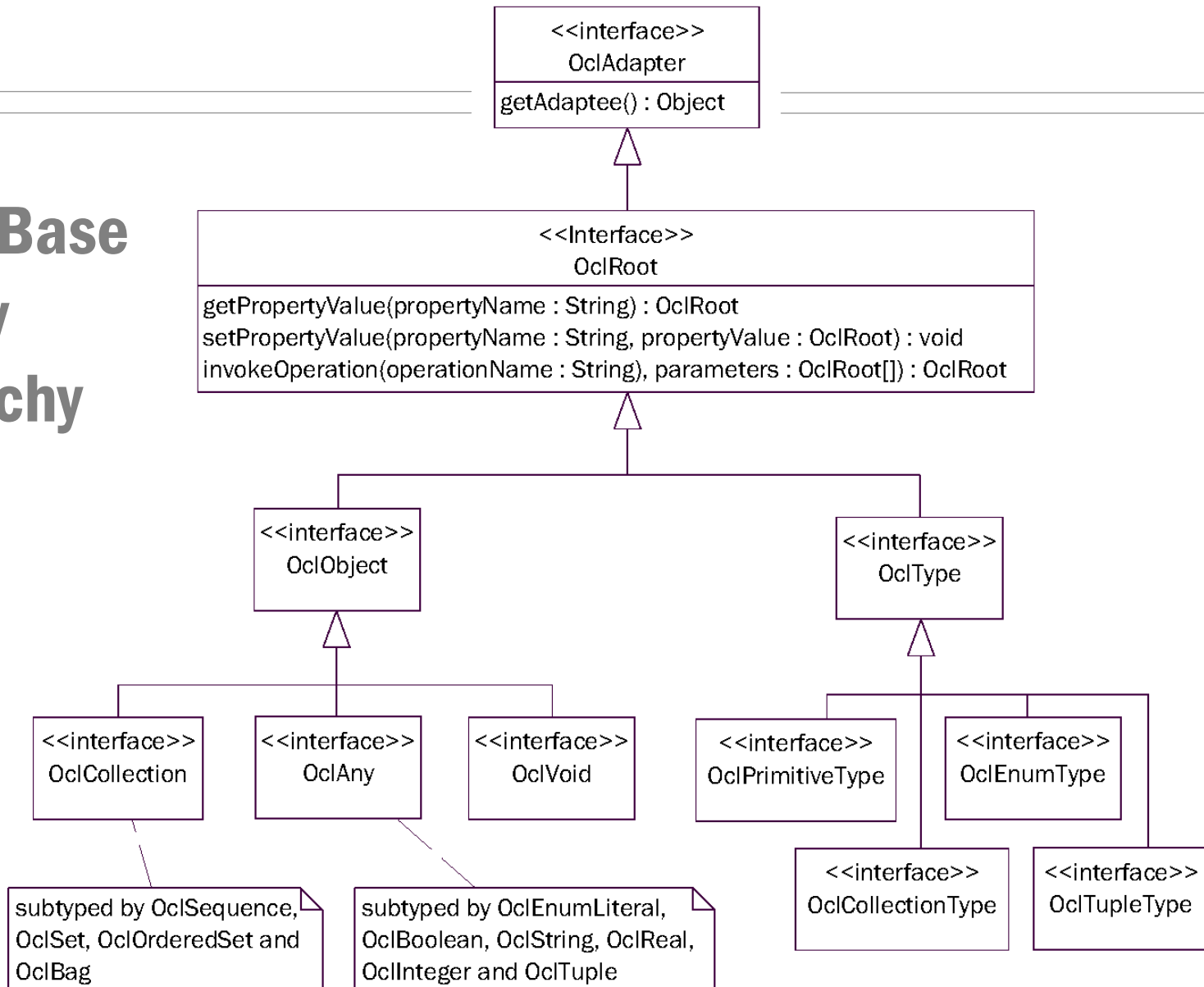

Adapt model elements to OCL types

- Adapter Factory
 - either as Singleton or via extension point
 - Hashtable lookup to find adapter for class
- Number of concepts relatively small
 - Object, Type, Enum, Collection, ...

Results

- Realizing the Pivot Concept
- **Prototypical Implementation**

Prototypical implementation

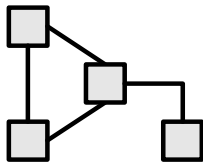

■ Concepts Level:

- Pivot Model and EssentialOCL in Rational Rose
- Generation of EMF interfaces / implementations
- Interfaces `IMetamodelService`, `IMetamodel` and corresponding extension point

Prototypical implementation

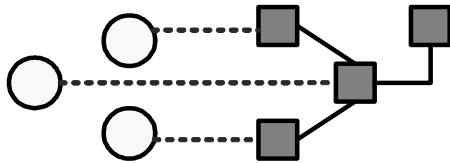

■ Definition Level:

- Model of Standard Library using Pivot Model Editor
- Manual integration with EMF
- Analysis of automatic generation of integration layer using annotations on an M2 model
- Interfaces `IModel`, `IModelFactory`

Prototypical implementation

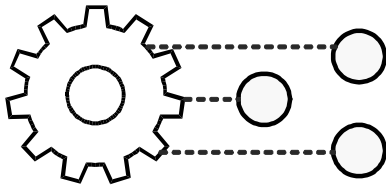

■ Execution Level:

- Interfaces `IModelInstance`, `IModelInstanceFactory`
- maybe experiments adapting to EMF
- ideas about automatic generation using dedicated mapping DSL instance as generator model

Contents

- Introduction
- Theoretical Foundations
- Tools and Technology
- Problem Analysis
- Related Work
- Results
- **Discussion**

Discussion

- Evaluation
 - no new ideas, but thorough analysis of existing work
 - many OCL Toolkit bugs spotted on the way

- Limitations
 - UML-specific aspects (state machines) neglected
 - prototypical nature of implementation

The End

- Thank you for your attention 😊
- Questions? Comments?

Backup

Design Principles

1. Include elements referenced by OCL specification
2. Remove redundant classes from UML
3. Remove superfluous attributes
4. Include elements from UML2 that lack in Core::Basic and limit OCL expressiveness
5. Follow UML2 naming, avoid name clashes
6. Mostly use interface inheritance
7. Add useful methods from the OCL Toolkit
8. Add methods defined in OCL specification
9. Add model manipulation methods

Pivot Model Features

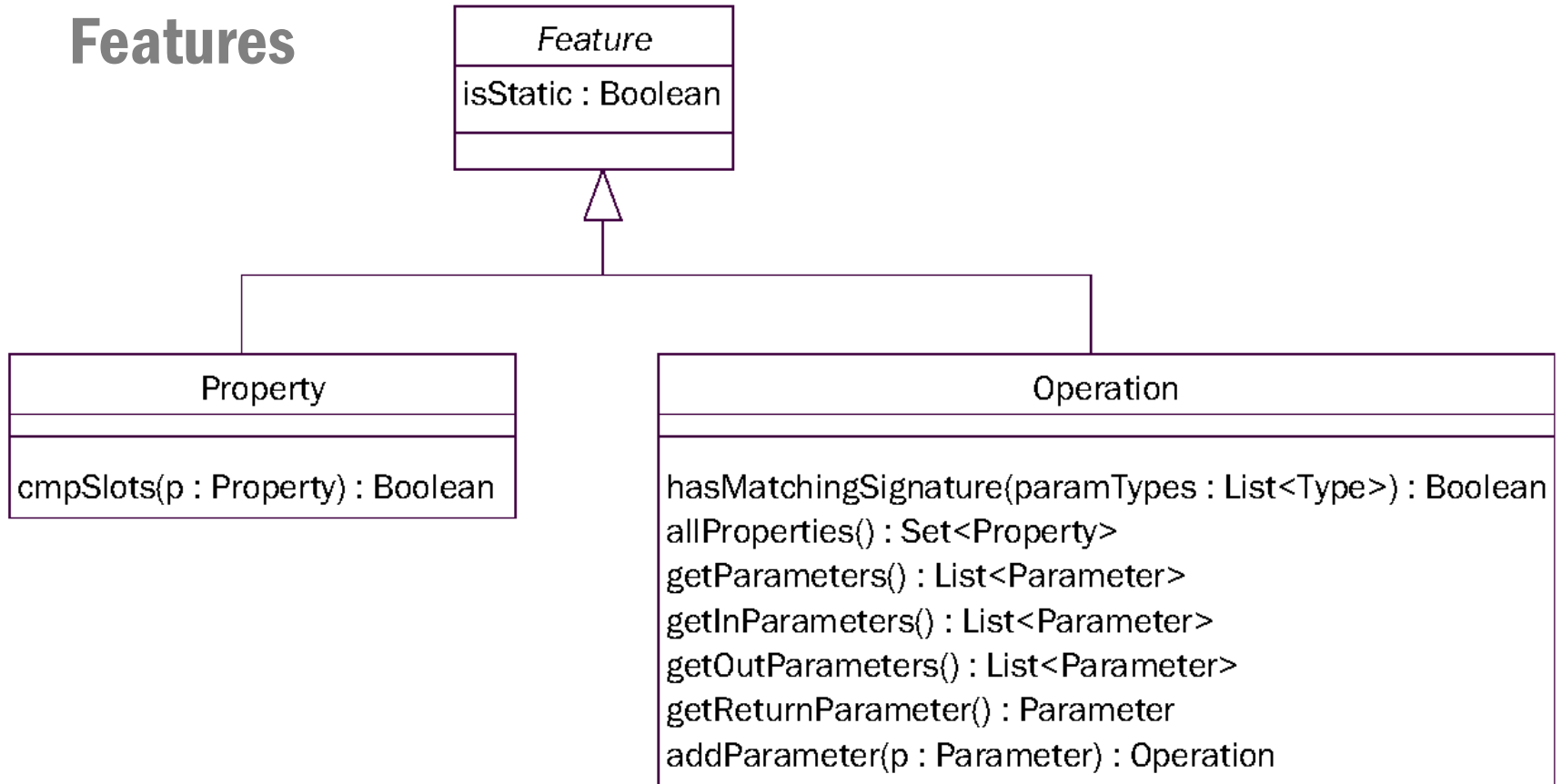

Pivot Model Multiplicity Element

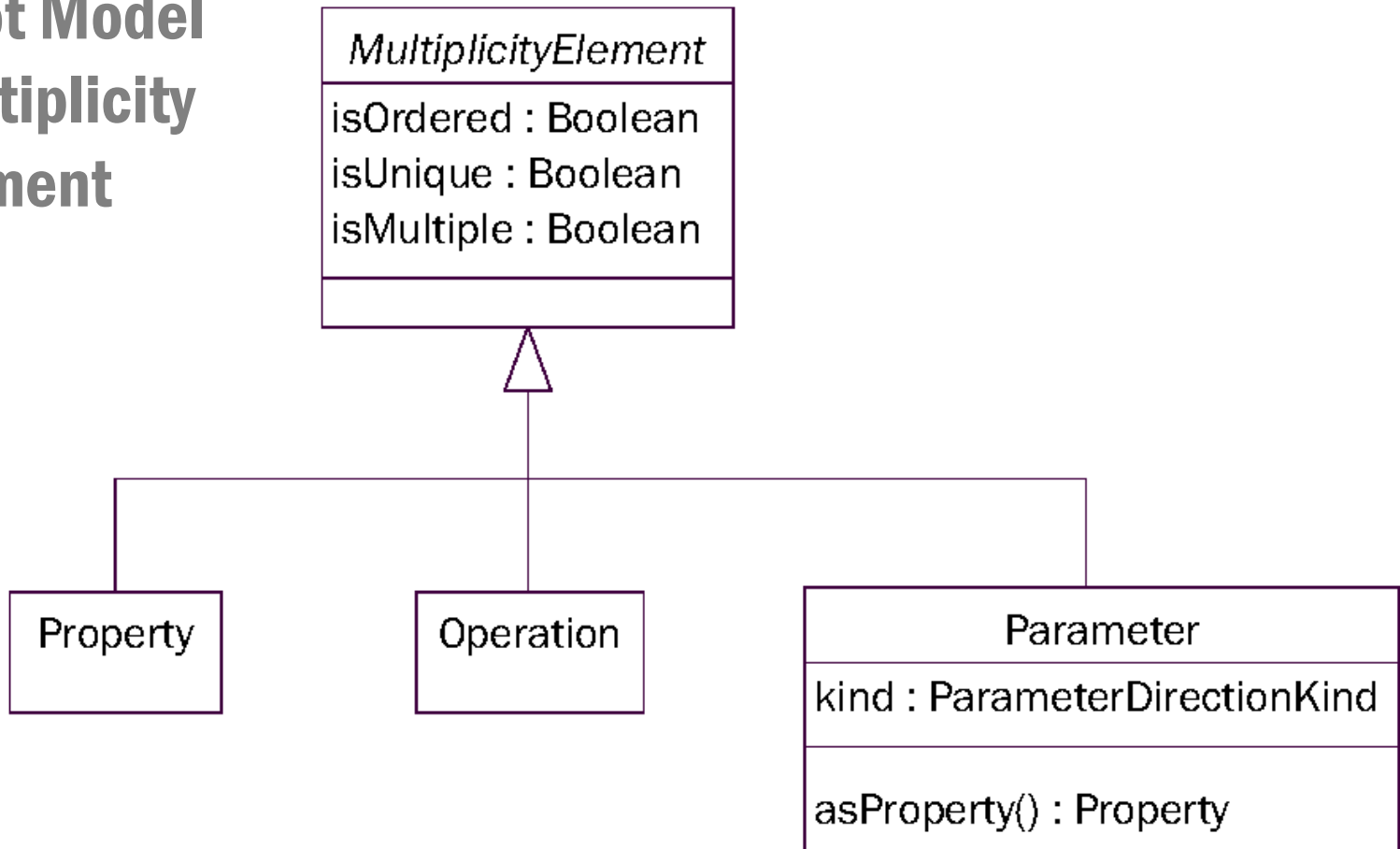

Pivot Model Type and TypedElement

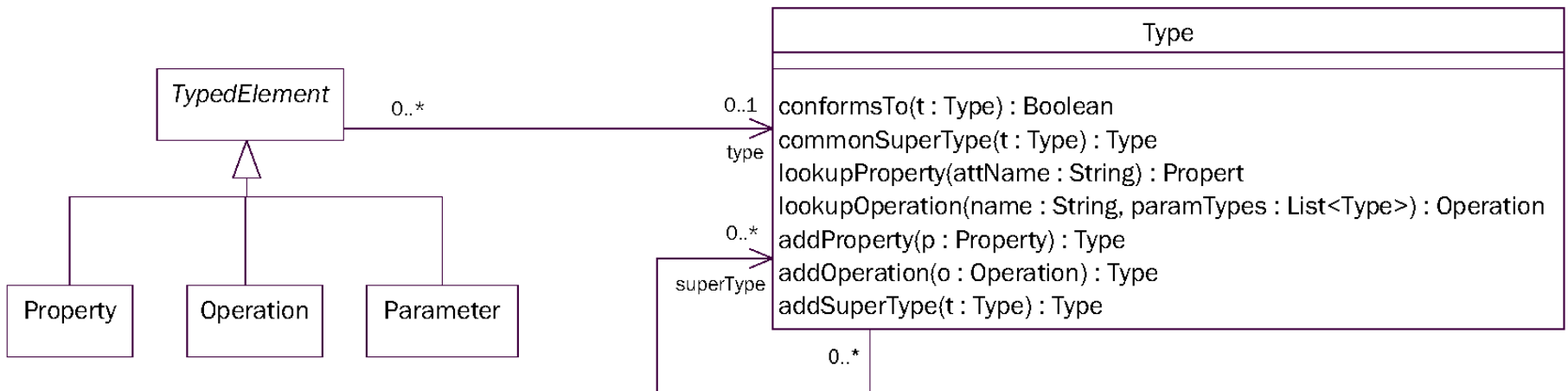

Pivot Model Constraints

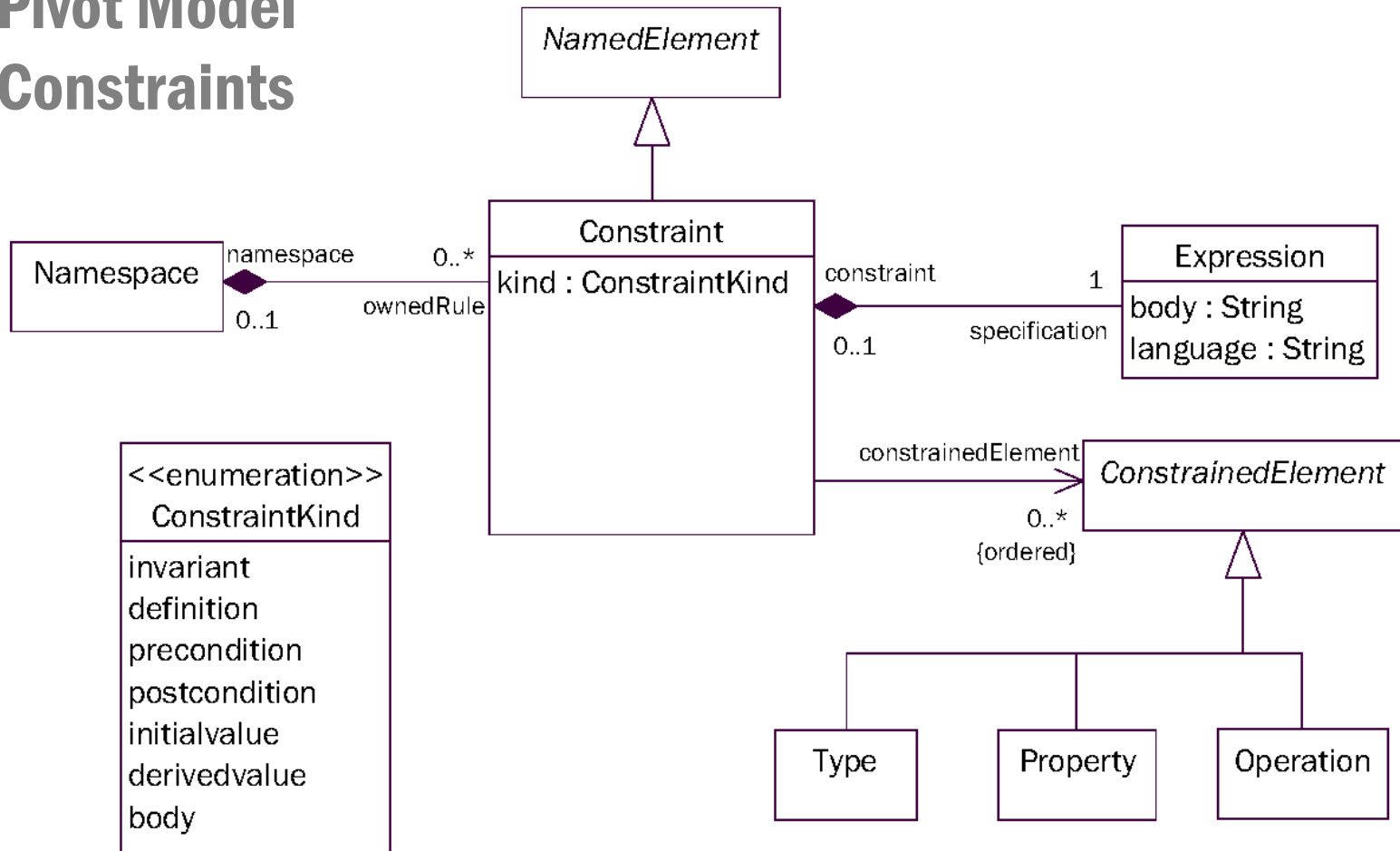

Datatype Adaptation in the Dresden OCL Toolkit

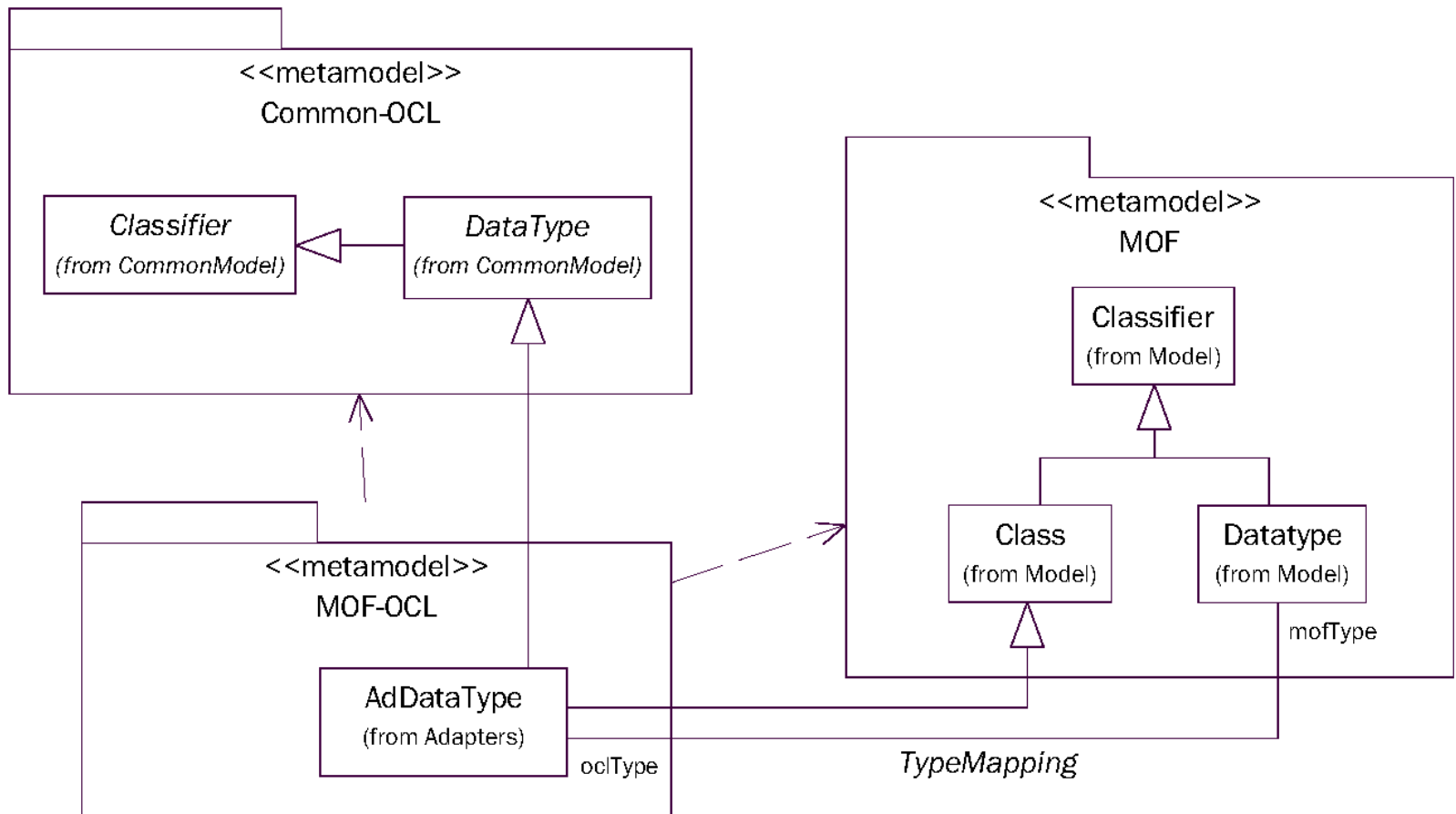

Definition Level in Kent OCL

- Adapters directly reference their repository-specific counterparts
- Creation of new adapters is delegated to a Factory

The current Dresden OCL Toolkit Base Library

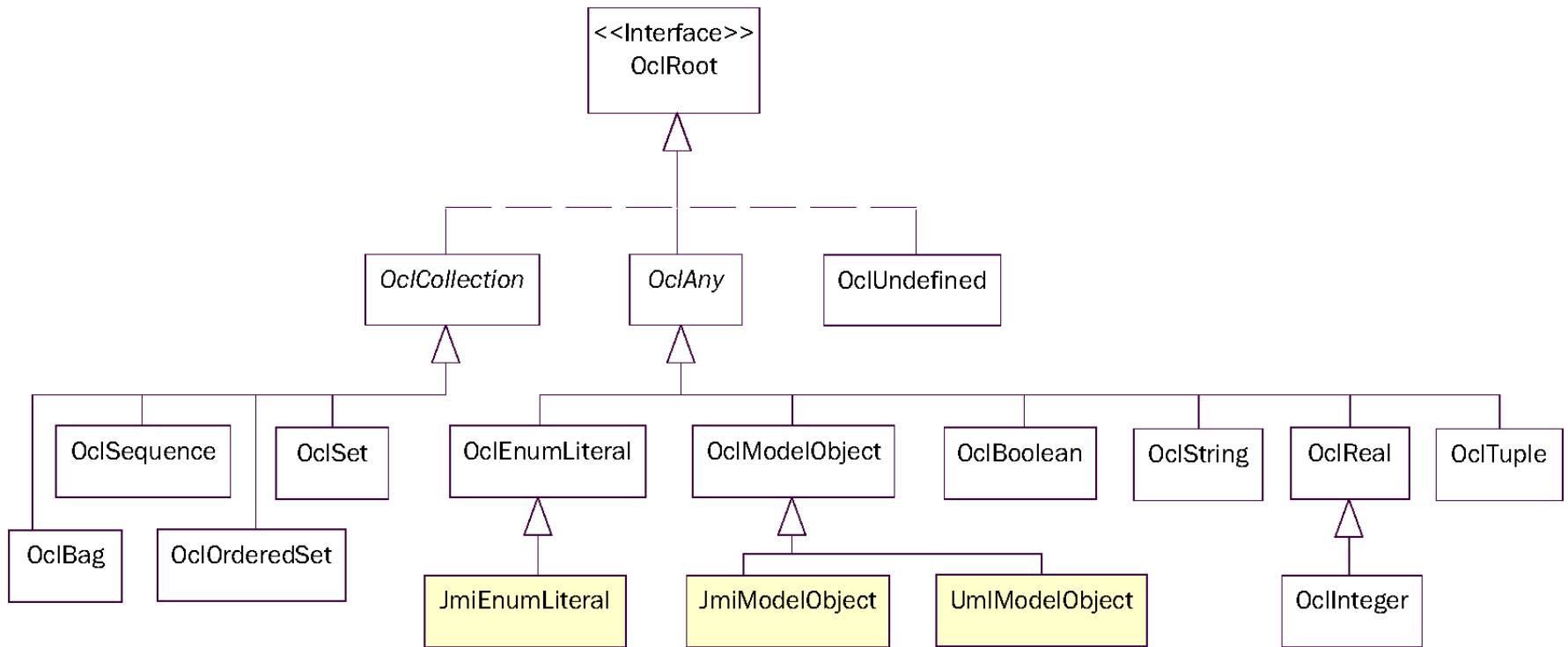

The current Dresden OCL Toolkit Base Library

